



MAURER Single Seal Expansion Joints



Design

MAURER Expansion Joints fulfil all load requirements such as German Standards (DIN), British Standards (BS) and American Standards (ASTM). They are generally approved by the German Federal Ministry of Transport.



Research and Development

Recognized throughout the world, Maurer has been one of the leading specialists of expansion joints for over 25 years. Intensive development work has been going on in close co-operation with competent research institutes forming the basis for the design of MAURER Expansion Joints. With their proven record of success worldwide Maurer is positioned to continue its acknowledged assistance to the construction industry – advancing the state-of-the-art.

Testing

Expansion joints are the dynamically heaviest loaded members of a bridge structure. They are directly exposed to traffic and thus subjected to forces and aggressions whose magnitudes or combinations are rarely found in structural engineering. They must withstand dynamic effects, impacts, fatigue, wear and chemical as well as physical aggression. To ensure long-term performance of MAURER Expansion Joints, extensive and continuous tests have been carried out on all major components prior to their release for fabrication.

The clear separation of the two major design principles on single seal joints, i.e. "rigid anchorage" and "watertight sealing" allows a proper design of both the components.

Rigid Anchorage

Some experts say: "An expansion joint is as good as its anchorage", and they are perfectly right. The edge beams are rigidly connected to the main structure by means of fatigue-tested anchors directly welded to the edge beams.

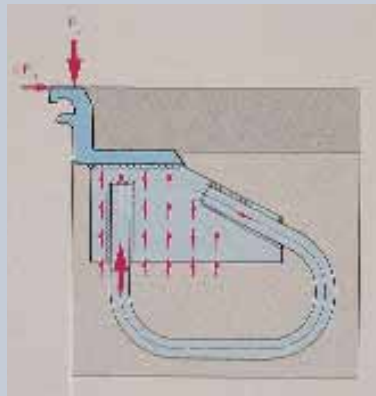

They are embedded into the reinforcement to assure the utmost resistance to the overrolling traffic. The use of screwed or bolted connections in the carriageway surface directly exposed to wheel loads must fail sooner or later. Such connections tend to fail under permanent dynamic traffic due to the lack of a controlled prestressing force, resulting in the need for regular maintenance, repair and replacement.

MAURER Joints have been developed in such a way as to clearly separate the load carrying and sealing function from each other. An expansion joint designed to fulfil all functions in one member must fail sooner or later. Carrying traffic, sealing the structural gap, accommodating movements (without substantial reaction forces) and disposing of a durable anchorage cannot be combined in one joint component only.



Watertightness

MAURER Expansion Joints feature an extremely effective insertion principle of the neoprene strip seal in the grooves of the edge beams without using any screwed or bolted connections. The special bulbous shape of the strip seal with its landing to a bead thickened end creates a wedge effect, when buttoned into the edge beam and guarantees absolute watertightness. Moreover, it can be easily inserted and replaced from the top of the road surface with simple tools and it can be connected together by means of hot-vulcanising even on site.



The strip seal is protected from the over-rolling traffic by the edge beams and its V-shape generates a self-cleaning effect. It can resist pulling forces and also accommodate lateral and vertical movements. The harmful effects of a leaking joint on a structure can be seen from the picture.



Joint Components

Hot-rolled steel sections and steel extrusions in grade St 37-2 and St 52-3 (DIN) are equivalent to S235 JR and S355 J2G3 (EN), to ASTM A 570 Grade

36 and ASTM A 738 respectively as well as to former British Standard BS 4360/37 and 4360/52.

Centre Beam No. 7.1002 Weight: 46.6 kg/m		Edge Beam EB No. 7.0009 Weight: 19.0 kg/m		X-Piece 80 No. 2.0080 Weight: 3.1 kg	
Edge Beam No. 7.0001 Weight: 18.2 kg/m		Edge Beam EB No. 7.0026 Weight: 7,5 kg/m		T-Piece 80 No. 2.0081 Weight: 2.3 kg	
Edge Beam 120 No. 7.1100 Weight: 27.3 kg/m		Edge Beam SS (stainless steel) No. 7.0078 Weight: 2.8 kg/m		L-Piece 80 No. 2.0082 Weight: 1.5 kg	
Edge Beam 40 No. 7.0003 Weight: 8.1 kg/m		Edge Beam AL (aluminium) No. 7.0073 Weight: 1.64 kg/m		↘-Piece 80 Weight: 1.5 kg	
Edge Beam 75 No. 7.0146 Weight: 10.7 kg/m		Strip Seal 80 No. 7.0011 Weight: 1.65 kg/m		Elastoblock 80 No. 7.0016 Weight: 5.5 kg/m (E-Block 100 upon request)	
Edge Beam BF No. 7.0112 Weight: 10.2 kg/m		Strip Seal 100 No. 7.0012 Weight: 1.75 kg/m (Seal 200 upon request)		Flush Seal 40 No. 7.0143 Weight: 13.4 kg/m (Seal 80 and 130 upon request)	
Edge Beam 70 No. 7.0008 Weight: 10.8 kg/m		Strip Seal 80G No. 7.0130 Weight: 1.45 kg/m		Compact Seal 30 (50) No. 7.0117 (7.0120) Weight: 2.0 (2,5) kg/m	

Inquiry Data

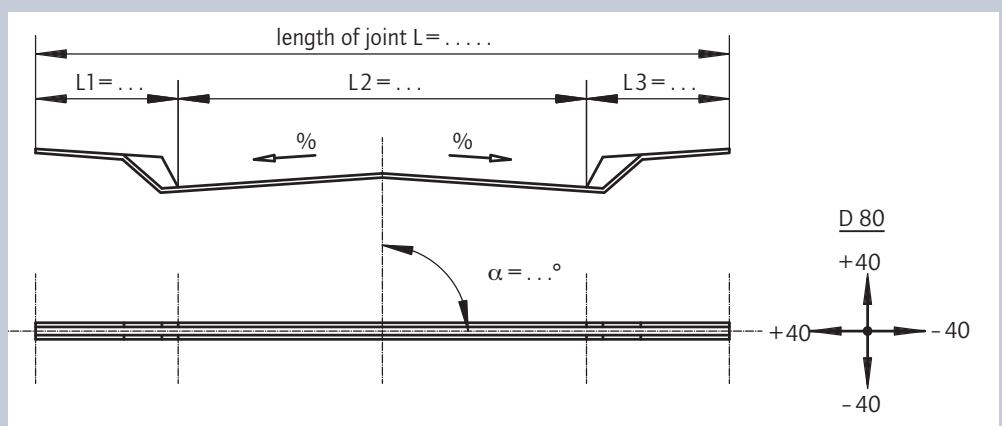

Design Varieties

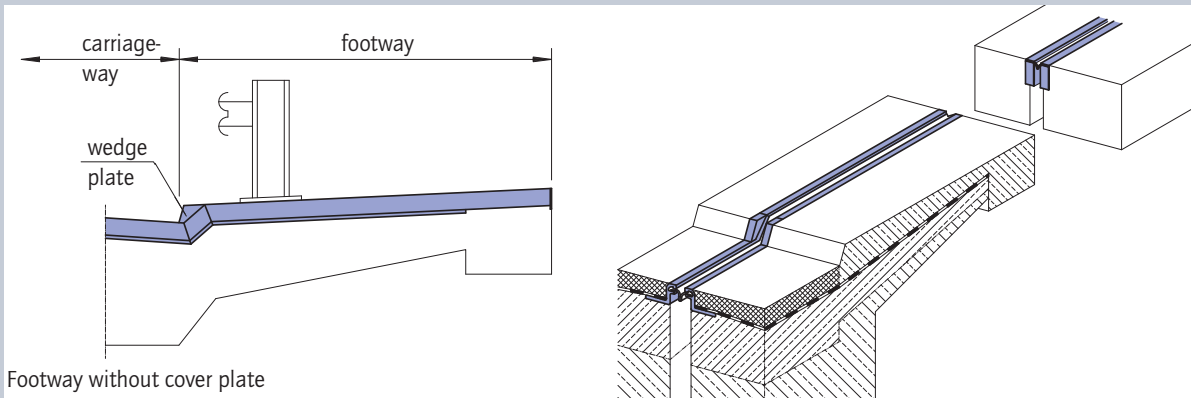

Footway without cover plate

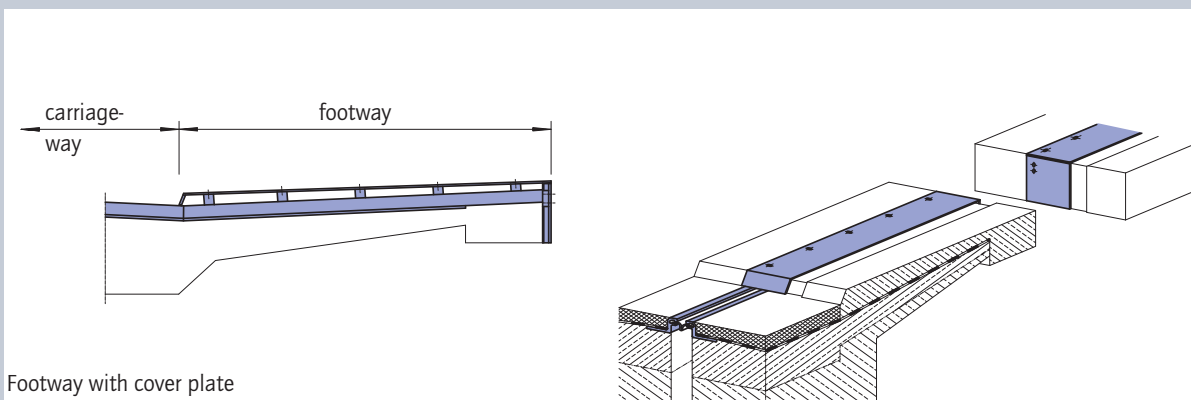

Footway with cover plate

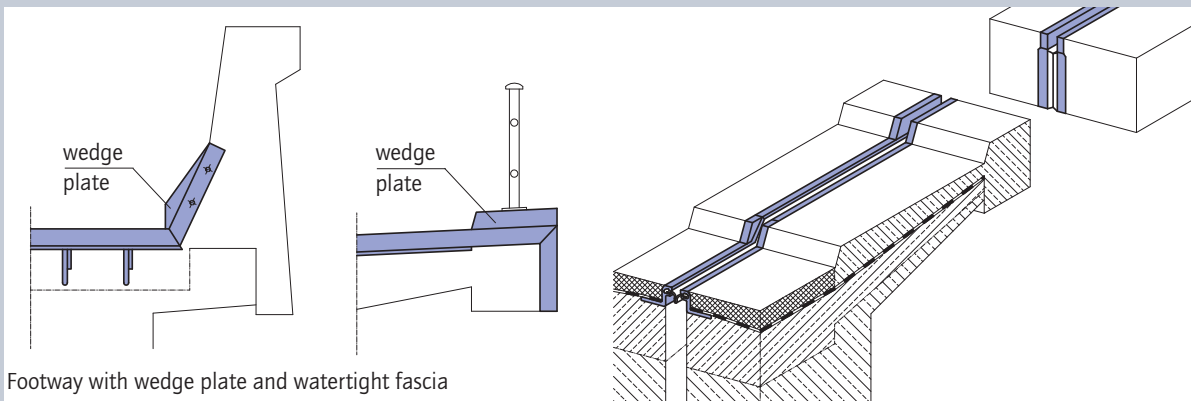

Footway with wedge plate and watertight fascia

On highways and expressways without footways the carriageway joints are usually provided with a vertical upturn at either end to prevent water from deteriorating the adjacent structural parts. Barrier cover plates can be provided at extra cost.

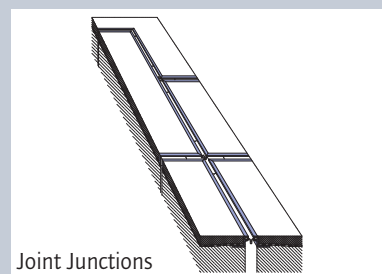
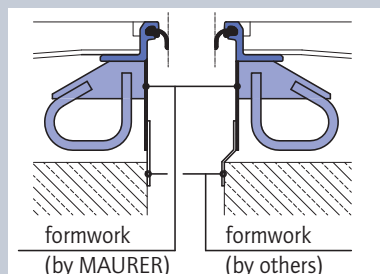

Joint Junctions

A permanent steel shuttering can be supplied at extra cost reaching to the lower part of the anchorage. The remaining gap between this shuttering and the blockout must be closed by structural measures. Please ask for a separate price if you wish a permanent steel shuttering.

The joint designs shown in this brochure were made as comprehensive as possible. However, there are still numerous details we could not refer to, for which we ask your specific inquiry.

Road and Highway Bridges

Carriageway Varieties

Fig.1

Should the bridge deck not allow for a blockout depth of 300 mm, the anchor size can be reduced to a certain extent. This also refers to locations where stressing heads impair full size anchors.

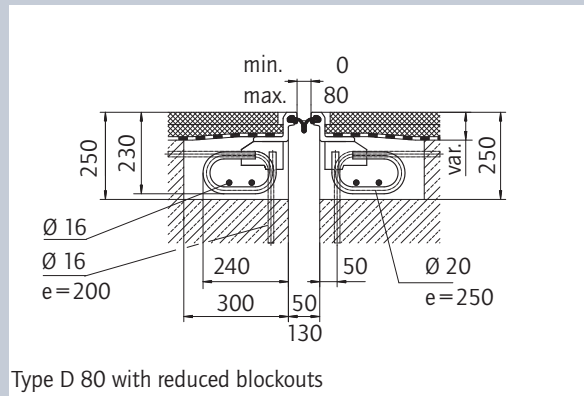

Type D 80 with reduced blockouts

Fig.2

In cases where the deck slab is extremely thin or for concrete surfaces, a modified anchorage will be provided. However, the anchoring concrete must be extended to the road surface forming a transition strip between the adjacent steel edge beam and the asphalt surface.

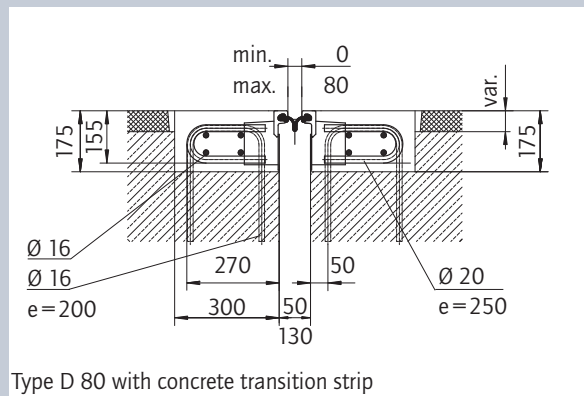

Type D 80 with concrete transition strip

Fig.3

A not everyday design is the adaption of the height of the steel edge beams to the asphalt surfacing which in principle can be done for any thickness at extra costs.

Please also refer to the page "Joint Components".

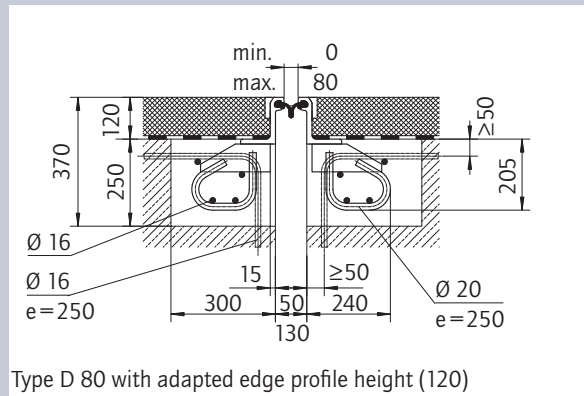

Type D 80 with adapted edge profile height (120)

Fig.4

The connection to steel bridges or else anchoring designs made of steel to be individually solved. Solutions that frequently appear are shown here.

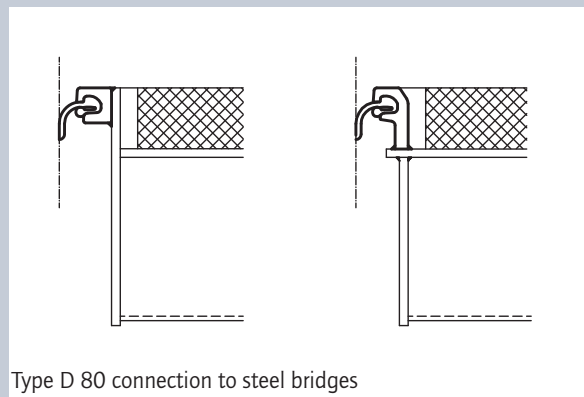

Type D 80 connection to steel bridges

Road and Highway Bridges

Footway Details

Fig.5

Standard blockout dimensions for type D 80 in footways with waterproofing membrane, avoiding cover plates. Joints without cover plates feature a more aesthetic appearance and facilitate inspection and maintenance. The open gap is safe for pedestrians.

Please also refer to the page "Design Varieties".

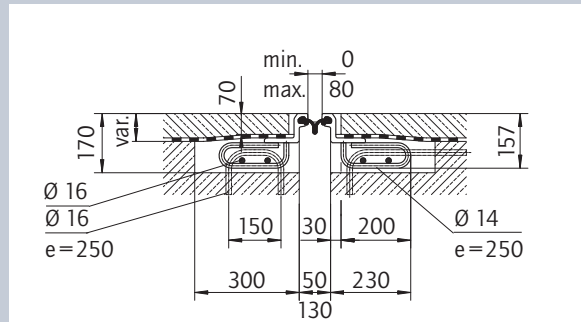

Footway joint

Fig.6

D 80 joint with footway cover plate and waterproofing membrane.

Please also refer to the page "Design Varieties".

Cover plates are susceptible to corrosion and promote ingress of water and dirt to joint underneath preventing natural exposure of the joint components to the weather all year round.

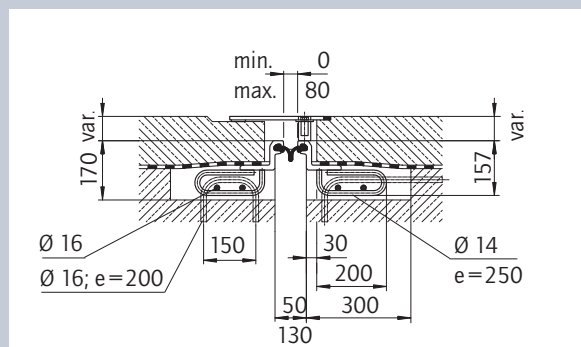

Footway joint with cover plates

Fig.7

Joint design for footways without waterproofing membrane and without cover plates. The steel edge beams do not show the horizontal ledge usually provided for structures with water proofing membrane.

Please also refer to the page "Joint Components".

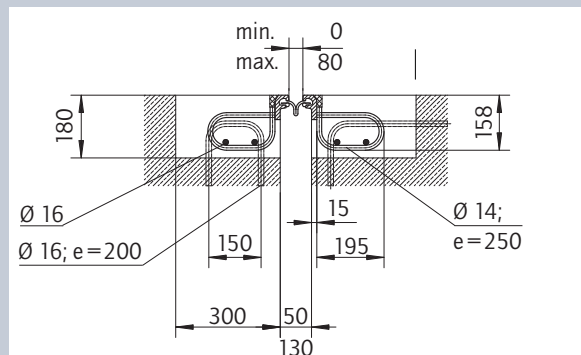

Footway joint without waterproofing membrane

Fig.8

Where service ducts located above the waterproofing membrane must be considered the joint elevation must be increased to not perforate the membrane. Holes will be provided in the edge beams to accommodate the service ducts. In structures without waterproofing membrane the service ducts can be lowered in the joint location and arranged underneath the blockout.

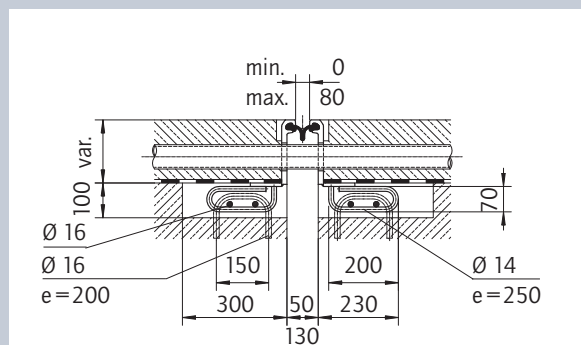

Footway joint with service ducts

Road, Rail & Commercial Structures

Type D 80 for road and highway bridges with standard blockout dimensions. Varieties of blockouts, anchoring systems as well as footway details are shown in this brochure.

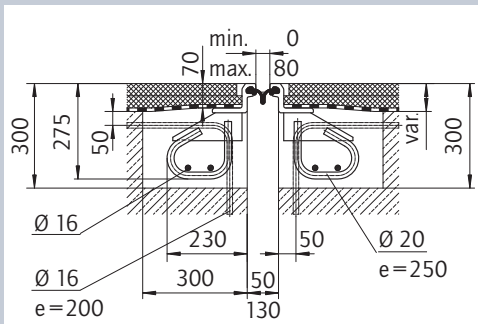

Standard strip seal joint D 80

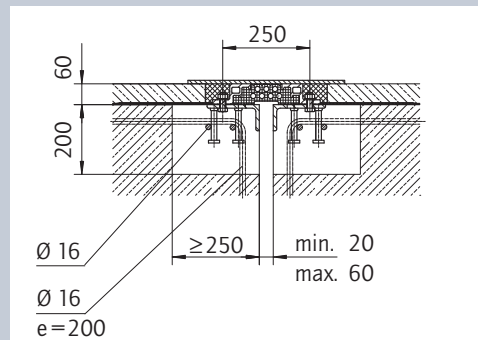

Railway joint DB 40

DB 40, DB 80 and DB 130 joints for movements of 40, 80 and 130 mm designed for railway bridges. Approved by German Railway Authority.

Betoflex®-Joints B 80 B are surface mounted and anchored into a cold processed polymeric concrete. Please ask for our pertinent brochure.

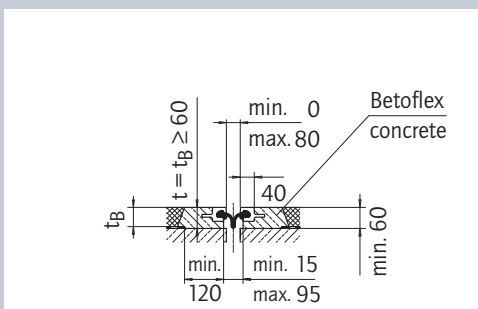

Betoflex®-Joint B 80 B

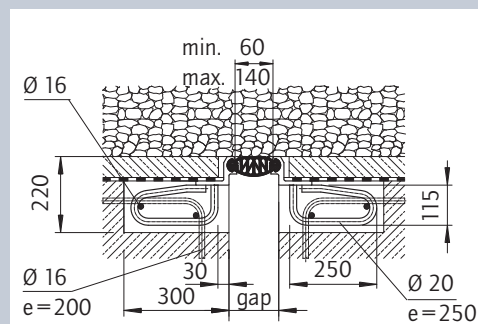

Railway joint DB 80 E

DB 80 E and DB 100 E elastoblock joints for movements of 80 and 100 mm, an alternative design for railway bridges.

K 30 N-K and **K 50 N-K** compact joints for 30 and 50 mm movement with stainless steel edge beams and anchor studs for commercial structures, carparks etc.

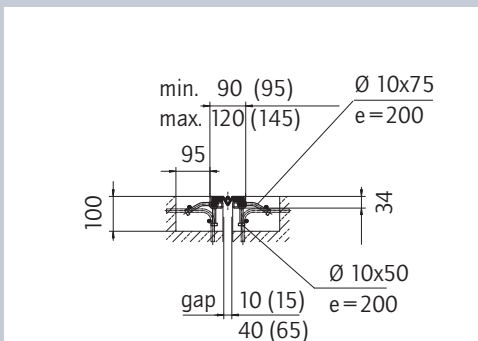

Compact joints K 30 (50) N-K

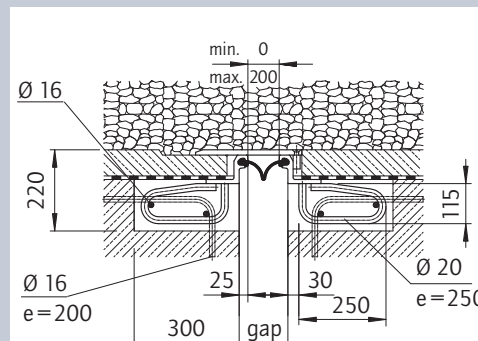

Railway joint DB 200

DB 200 joint for movements of up to 200 mm for railway bridges with a sliding plate above the sealing element.

K 30 A-B and **K 50 A-B** compact joints see fig. above, however, with aluminium edge beams and anchored into Betoflex®. Please ask for our pertinent brochure.

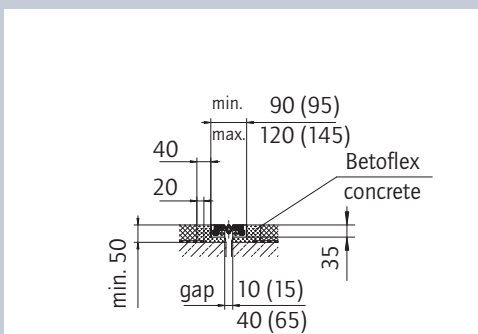

Compact joints K 30 (50) A-B

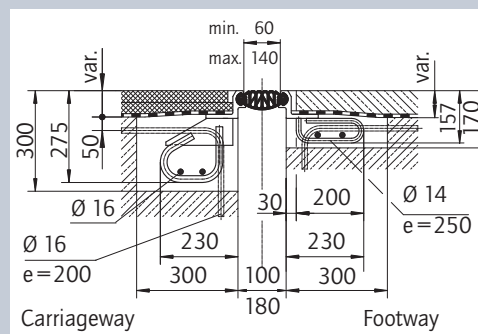

Elastoblock joint D 80 E

D 80 E and D 100 E elastoblock joints for road and pedestrian bridges.

References

Bearing in mind that the amount of money spent on expansion joints in bridges comes up to approximately 1.5% of the total structural costs only, it is certainly short-sighted to evaluate solely the purchase price of these important bridge members. The initial savings can generate tremendous costs later on, if the joint system chosen fails.



Maurer Söhne head office
Frankfurter Ring 193, 80807 Munich/Germany
P.O. Box 44 01 45, 80750 Munich/Germany
phone: +49 89 32394-0
fax: +49 89 32394-306
ba@maurer-soehne.de
www.maurer-soehne.de

Maurer Söhne branch office
Zum Holzplatz 2, 44536 Lünen/Germany
P.O. Box 63 40, 44520 Lünen/Germany
phone: +49 231 43401-0
fax: +49 231 43401-11
info@nd.maurer-soehne.de

Maurer Söhne subsidiary
Kamenzer Str. 53, 02994 Bernsdorf/Germany
P.O. Box 55, 02992 Bernsdorf/Germany
phone: +49 35723 237-0
fax: +49 35723 237-20
info@bd.maurer-soehne.de